

STEEL COVER NOTE:

1. ALL STEEL FABRICATION SHALL BE IN ACCORDANCE TO AWA D1.1 STEEL SHALL BE ASTM A36 CARDAN STEEL, AND HOT DIPPED GALVANIZED AFTER FABRICATION IN ACCORDANCE TO ASTM A123. STANDARD COVER IS RATED FOR 50 PSI.

ENGINEERING DATA:

1. THE BACKFLOW ASSEMBLY SHALL BE FACTORY ASSEMBLED IN VAULT & HYDROSTATICALLY TESTED PRIOR TO DELIVERY.

PLAN VIEW

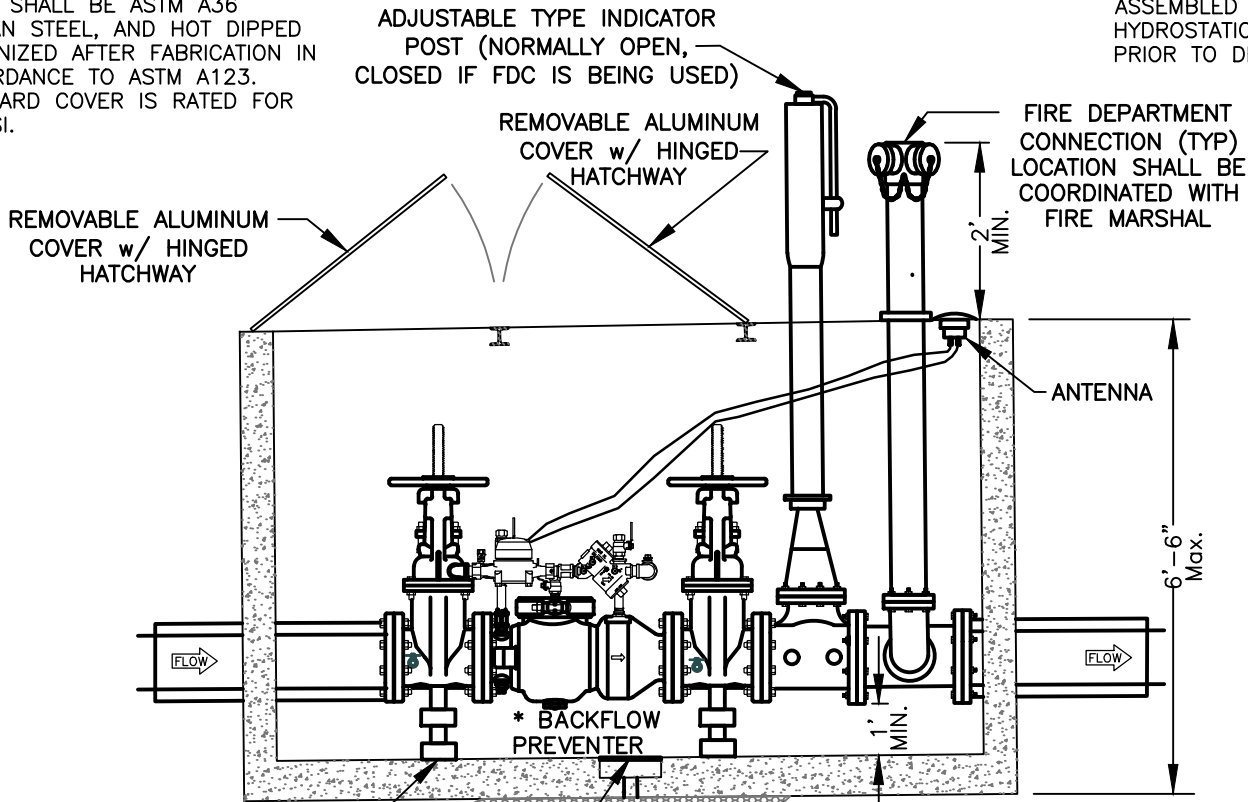

GALVANANIZED STEEL SUPPORT (TYP)

12" x 12" SUMP w/CAST IRON GRATE

GRAVEL BED 6" MIN.

PROFILE VIEW

CONCRETE BOXES NOTES:

1. A36 STEEL SKID-RESISTANT COVER & FRAME w/24" x 32" HINGED MANWAY
2. WITH TAMPER SWITCH ON OS&Y VALVES.
3. CONCRETE BOXES TO BE CLASS 1 CONCRETE WITH DESIGN STRENGTH OF 4500 PSI AT 28 DAYS. UNIT IS OF MONOLITHIC CONSTRUCTION AT FLOOR AND FIRST STAGE OF WALL WITH SECTIONAL RISER TO REQUIRED DEPTH.
4. GRADE 60 REINFORCED. STEEL REBAR CONFORMING TO ASTM A615 ON REQUIRED CENTERS OR EQUAL.
5. ASSEMBLY SHALL NOT BE LOCATED WITHIN R.O.W. OR PUBLIC EASEMENT.

*** DOUBLE CHECK DETECTOR ASSEMBLY**

1. ZURN/WILKINS MODEL 350 DA
2. WATTS SERIES 757 DCDA
3. OR APPROVED EQUAL.

THE CITY OF ROSENBERG, FORT BEND COUNTY, TEXAS
 DEPARTMENT OF PUBLIC WORKS
 FIRE SERVICE CONNECTION
 WITH FLOW
 PREVENTER ASSEMBLY

DESIGN: CAK	CAD: STAFF	SCALE: NTS	DATE: 05/22	DRAWING: W-112
----------------	---------------	---------------	----------------	-------------------